



240,000BTU/HR, 340,000BTU/HR SPACE WARMER® KEROSENE/DIESEL HEATER WITH WHEELS

MODEL NOS: **AB2380, AB3412.V2**

Thank you for purchasing a Sealey product. Manufactured to a high standard, this product will, if used according to these instructions, and properly maintained, give you years of trouble free performance.

IMPORTANT: PLEASE READ THESE INSTRUCTIONS CAREFULLY. NOTE THE SAFE OPERATIONAL REQUIREMENTS, WARNINGS & CAUTIONS. USE THE PRODUCT CORRECTLY AND WITH CARE FOR THE PURPOSE FOR WHICH IT IS INTENDED. FAILURE TO DO SO MAY CAUSE DAMAGE AND/OR PERSONAL INJURY AND WILL INVALIDATE THE WARRANTY. KEEP THESE INSTRUCTIONS SAFE FOR FUTURE USE.



Refer to instructions



Warning!
Automatic start-up



Hot surfaces



Warning!



Do not cover



Electrical shock hazard

THIS PRODUCT IS NOT SUITABLE FOR PRIMARY HEATING PURPOSES

1. SAFETY

1.1. ELECTRICAL SAFETY

- WARNING!** It is the user's responsibility to check the following:
- ✓ Check all electrical equipment and appliances to ensure that they are safe before using.
- ✓ Inspect power supply leads, plugs and all electrical connections for wear and damage.
- ✓ Ensure that the insulation on all cables and on the appliance is safe before connecting it to the power supply.
- ✗ **DO NOT** use worn or damaged cables, plugs or connectors.
- ✓ Ensure that any faulty item is repaired or replaced immediately by a Sealey qualified technician.
- ✓ If the cable or plug is damaged during use, switch off the electricity supply and remove from use.
- ✓ Sealey recommend that an RCD (Residual Current Device) is used with all electrical products.
- Important:** Ensure that the voltage rating on the appliance suits the mains power supply.
- ✗ **DO NOT** pull or carry the appliance by the power cable.
- ✗ **DO NOT** pull the plug from the socket by the cable.

1.2. GENERAL SAFETY

- ▲ **DANGER!** Risk of carbon monoxide poisoning. Failure to provide proper ventilation could result in serious illness or death.
- ✓ Check that the heater is in sound condition and good working order. Take immediate action to repair or replace damaged parts.
- ✓ Use recommended parts only. Unapproved parts may be dangerous and will invalidate the warranty.
- ✓ Only use clean kerosene or diesel (NOT BIO-DIESEL) to fuel your heater, in accordance with instructions contained in this manual.
- WARNING!** Only use heater in well ventilated areas. Ensure continuous ventilation from outside of the building is provided to the heater operating area. Allow at least 3ft² opening/100000Btu/hr output.
- ✓ Keep the front of the heater a minimum of 2.4 metres and the rear and sides 1.2 metres from any combustible materials (i.e. wooden items, cloth, plastics, paper, tarpaulins or similar enclosure materials).
- ✓ Only operate on a level and stable surface.
- WARNING! DO NOT** use the heater near flammable material, liquids, solids, gases or compressed gas cylinders.
- ✗ **DO NOT** use the heater in closed rooms, living areas, basements or below ground level.
- ✗ **DO NOT** allow untrained persons to operate the heater and **DO NOT** operate the heater without the cover.
- ✗ **DO NOT** move or handle the heater when hot.
- ✗ **DO NOT** leave the heater unattended when in use. Switch the heater off and unplug from the mains before leaving work area.
- ✗ **DO NOT** fill the fuel tank whilst the heater is running or still hot.
- ✗ **DO NOT** overfill the fuel container. Wipe up any spilt fuel immediately.
- ✗ **DO NOT** obstruct the air inlet (rear) and air outlet (front) of the heater. **DO NOT** use duct work in front or at the rear of the heater.
- ✗ **DO NOT** look into the exhaust end of the heater.
- ✗ **DO NOT** allow children or animals near the heater when in use, or while hot.
- WARNING! RISK OF ELECTRIC SHOCK. DO NOT** expose the heater to water spray, rain, dripping water or wind.
- ✗ **DO NOT** operate the heater when you are tired or under the influence of alcohol, drugs or intoxicating medication.
- ✗ **DO NOT** touch the heater outlet or dome when first switched off as these are very hot and will take time to cool.
- ✓ Ensure that the heater is correctly turned off when not in use and store in a safe, dry area, out of reach of children.
- ✗ **DO NOT** unplug the heater to switch it off. Use the ON/OFF switch.
- WARNING!** Improper maintenance can lead to poor combustion and soot production

NOTE:

- This appliance is not intended for persons (including children) with reduced physical, sensory or mental capabilities, or lack of experience and knowledge, unless they have been given supervision or instruction concerning use of the appliance by a person responsible for their safety. Children should be supervised to ensure that they **DO NOT** play with the appliance.
- ✓ Unplug the heater before moving it. Never pull the cable to unplug or move the unit.
- ✗ **DO NOT** leave the heater unattended when in use.
- ✗ Never use the appliance with wet hands or when either the heater or the power cable is wet.
- ✓ If the supply cable is damaged, it must be replaced by the manufacturer, by a service agent or a similar qualified person.
- WARNING!** The warnings, cautions and instructions in this manual cannot cover all possible conditions and situations that may occur. It must be understood by the operator that common sense and caution are factors which cannot be built into this product, but must be applied by the operator.

- ❑ **WARNING!** Air contaminants taken into the heater may affect the heat output, damage the unit and may cause health problems. Example: Bodyshop filler dust or paint overspray will damage the motor bearing, clog the filter and compressor and contaminate the combustion chamber causing flame flutter and health hazards. Please note that any parts damaged by filler dust or overspray will not be covered by warranty.

2. INTRODUCTION

Workshop tried and tested, our range of Kerosene/Diesel heaters represents excellent value. All models have a digital adjustable thermostat (°C) and are also fitted with digital room temperature (°C) display/error code read-out. Proven pump systems handle either kerosene or diesel with only minor adjustment of air compressor. All models are fitted with a fuel tank gauge. Fitted with fuel tank drain plug, sturdy handle and heavy-duty wheels for easy manoeuvrability. Equipped with automatic shut off, cable storage on handle plus Danfoss oil nozzle and gear pump for stable fuel delivery.

3. SPECIFICATION

MODEL NO.	AB2380	AB3412.V2
Airflow (cfm)	765	825
Electrical fuse rating	13A	
Electrical Plug type	3-pin BS	
Fuel	Kerosene/Diesel	
Fuel tank	69L	
Heated area	70,600ft ³ (2000m ³)	88,200ft ³ (2500m ³)
Motor power	430W	
Output	240,000Btu/hr(70kW)	340,000Btu/hr (100kW)
Running time per filling (max.)	10hr	7hr
Supply	230V - 13A	
Transport wheels	Yes	

4. CONTENTS

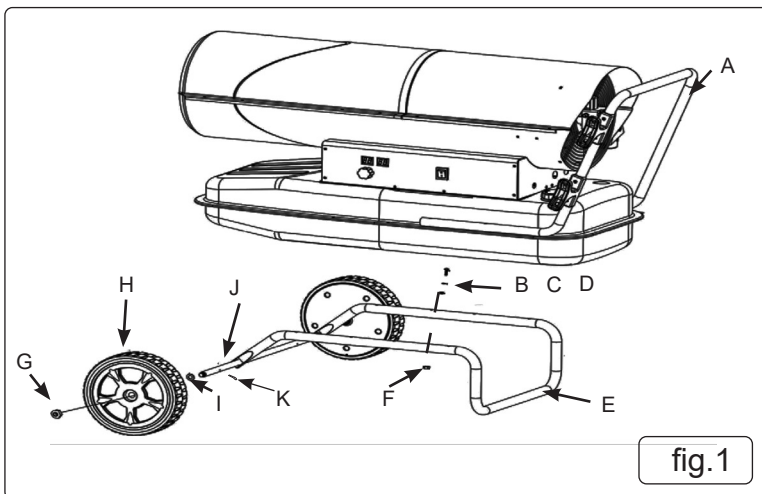

No.	Description	Qty.
A	Handle	1
B	Screw	10/12
C	Spring washer	6/8
D	Plain washer	10/12
E	Frame	1
F	Nut M5	10/12
G	Nut M12	2
H	Wheel	2
I	Plain washer Ø12	2
J	Axle	1
K	Split pin	2

5. ASSEMBLY

- 5.1. Remove heater from carton.
- 5.2. If unit is damaged in any way **DO NOT** use and contact the Supplier.
- 5.3. **ASSEMBLY** (fig.1)
To assemble the heater, proceed as follows (see Fig. 1):
 - 5.3.1. Insert the axle J to the corresponding hole of frame E and insert the split pins K to the corresponding holes.
 - 5.3.2. Slide plain washer I onto the axle up to the sides of the frame.
 - 5.3.3. Slide the wheel H over the axle J and screw the nut G onto the end of the axle to fix the wheel in place ensuring that it can rotate freely and securely.
 - 5.3.4. Put the heater body on the frame assembly, make sure the 4 holes of handle A point towards the corresponding 4 holes on the frame respectively.
 - 5.3.5. Using the screw B, spring washer C, plain washer D and nut F to securely fix the frame to the tank.

6. INSTALLATION

- 6.1. Position the heater on a flat, level, non-flammable, solid surface.
- 6.2. The exhaust gases are very harmful for people and animals when released in a closed space without ventilation.
- 6.3. Indirect-fired heaters while used in indoor installation, must be connected to an exhaust pipe to vent the products of combustion outside. To maintain an adequate Oxygen rate, a minimum of 80 m³/h airflow from outside must be ensured.
- 6.4. Direct-fired heaters are intended for use in outdoor open areas or in indoor well ventilated areas. For indoor use, provide permanent ventilation openings of at least 25 cm²/kW, equally distributed between floor and high level, with a minimum of 250 cm².

Model No.	AB2380	AB3412
Minimum Opening Size	1750 cm ²	2100 cm ²

- ✓ Only install the heater in normal upright position.
 - ✗ **DO NOT** place the heater near walls, corners or low ceilings.
 - ✗ **DO NOT** place the heater below a socket outlet.
 - ✗ **DO NOT** place the heater on moving vehicles or where it can tip over.
 - ✓ Keep the heater away from flammable, combustible, explosive or corrosive materials.
 - ✓ Keep the heater away from curtains or similar materials that could block the air inlet and outlet.
 - ✓ Never block or restrict the air inlet and outlet for any reason.
 - ✓ Keep the power cable away from heat sources, sharp edges, cutting and moving parts.
 - ✗ **DO NOT** expose directly to the weather or to excessive humidity.
 - ✗ **DO NOT** place the heater in the immediate surroundings of a bath, shower or swimming pool.
- Follow general and special fire safety regulations in force in all fields of applications. In any case ensure the following minimum safety clearances from materials or objects in the surroundings of the heater:

Side: 1 m
 Air inlet side: 1 m
 Top: 1.5 m
 Hot air outlet side: 3 m

- ✓ Floors and ceilings must be made of fireproof materials in the place where the heater is operated.
- ✗ **DO NOT** connect direct-fired heaters to air ducts.

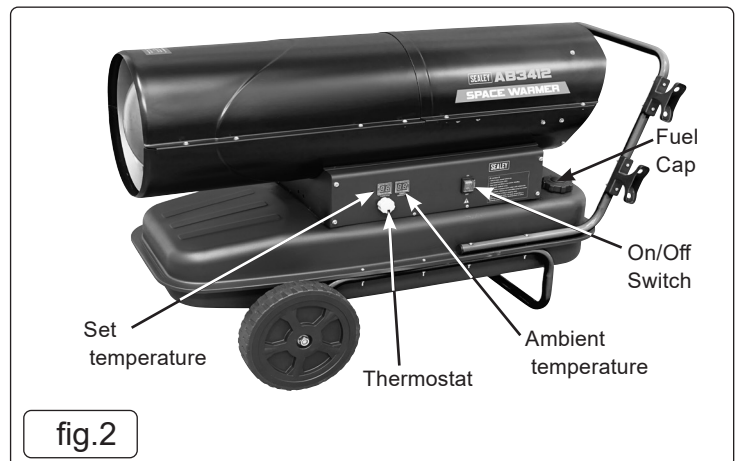

fig.2

11. OPERATION

11.1. START-UP

- 11.1.1. Fill tank with clean fuel. Only use diesel or kerosene.
- 11.1.2. Check fuel level using The fuel gauge on top of the tank.
- 11.1.3. Connect the power cable plug to a AC220V-240V 50 Hz earthed electrical supply system.
 - ☐ **WARNING!** Earthing is mandatory.
- 11.1.4. After completing "start-up" steps above, the left display window shows "--", the right display window shows the ambient temperature value.
- 11.1.5. Push the power switch to "on" position.
- 11.1.6. The default 'set temperature' is 20°C, it is displayed on the left hand window.
- 11.1.7. If the ambient temperature is lower than default temperature, after waiting for 12 seconds per-ventilation, the heater starts.
- 11.1.8. If the ambient temperature is higher than default temperature, turn thermostat control knob to desired temperature. After waiting for several seconds pre-ventilation, the heater starts.
 - ☐ **WARNING! ABNORMAL OPERATION:** in case of malfunction (flame failure, reduced air flow, bad combustion, etc.) the heater will stop, the LOCK-OUT MODE code will be shown on the display window; see Troubleshooting.

11.2. MANUAL RESET/RESTART

- 11.2.1. If the heater is in lock-out mode, check and resolve the cause of lock-out before restarting the heater. To reset, turn the ON/OFF switch to 0 and then (after 30 sec) turn the ON/OFF to I. In case of repeated malfunction, call Technical Service. Turning the thermostat control knob will NOT reset the heater.

11.3. SHUT-DOWN

- 11.3.1. Move switch to "OFF" (O) position. The post-ventilation phase will cool down the combustion chamber for 90 seconds. Unplug the unit when not used for a long time.
 - ✗ **DO NOT** disconnect the heater from mains to stop it while in operation. Always allow the cooling sequence to be completed, otherwise the residual heat could damage internal components.
 - ✗ **DO NOT** cover the heater. **DO NOT** block the air inlet and outlet.
 - ✗ The heater outlet is very hot during operation and after use. **DO NOT** touch! Use personal protecting equipment if needed.

12. MAINTENANCE

- ✓ Regularly wipe the cover using a soft sponge or cloth. For very dirty parts, use a sponge wetted with lukewarm water and a mild detergent, then dry using a clean cloth.
- ✓ Keep air inlet and fan free from dust and dirt. To clean inner parts, gently blow compressed air through air inlet.
- ✓ Regularly inspect the power cable: if worn, cracked or damaged have it replaced by technical service.
- ✓ Before storing the heater, make sure it is perfectly cool and dry. Cover the unit with a plastic bag, put it in its packing box and store it in a dry, ventilated place.
- ✓ Before starting any maintenance task, shut down, unplug and let the heater cool down for at least 15 minutes.
- ✗ **DO NOT** attempt any electrical repair yourself. If the heater needs service or repair, contact a qualified technician.
- ✗ **DO NOT** use a faulty unit unless a qualified technician has inspected and repaired it.
- ✓ When cleaning, make sure that water does not enter the unit.
- ✗ **DO NOT** open the enclosure to clean the inner parts. **DO NOT** spray water into the heater.
- ✓ Never use solvents, gasoline, toluene and similar aggressive chemicals to clean the heater.

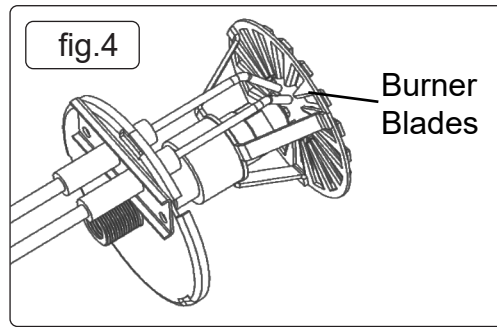
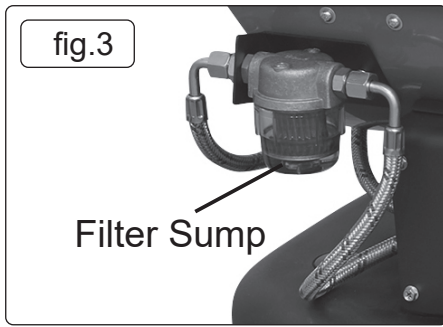

NOTE: The following checks BY QUALIFIED PERSONNEL ONLY are recommended before every seasonal use:

12.1. FUEL FILTERS

12.1.1. Clean fuel filters by unscrewing the filter tray (clockwise) Remove the filter cartridge and wash it with petrol or replace it if necessary. Check seal O-ring and replace it if necessary. Reassemble the sump (Fig.3). The fuel filter installed on the gear pump should be cleaned or replaced if necessary by unscrewing cap H (see Fig.6)

12.2. EXTRACT THE BURNER HEAD FIG.4

12.2.1. BURNER BLADES

12.2.2. Clean the burner blades (Fig.4) by using a brush and then blowing compressed air on them. To get good combustion, the air flow openings in the whirl disc should be perfectly clean and free.

12.3. NOZZLE

12.3.1. Carefully unscrew nozzle from nozzle fitting. Blow compressed air through nozzle orifice to free it from dirt. Replace nozzle if necessary.

12.4. IGNITION ELECTRODES

12.4.1. Clean, adjust and if necessary replace ignition electrode. For electrode gaps see Fig.5 (dimensions in mm).

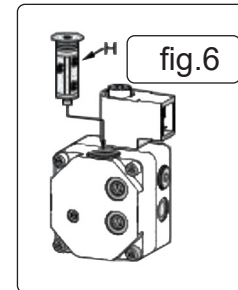
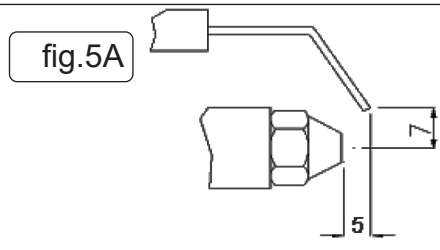
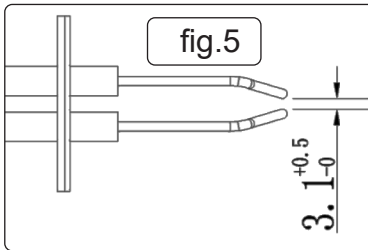

12.5. AIR COLLAR AND FUEL PRESSURE ADJUSTMENT (FIG.6, FIG.7)

12.6. The air collar and fuel pressure settings are factory set and must be checked and adjusted by qualified technicians only. Tampering with the unit may be dangerous.

12.7. ELECTRICAL INSPECTION

12.7.1. Inspect cables, electrical parts and connections.

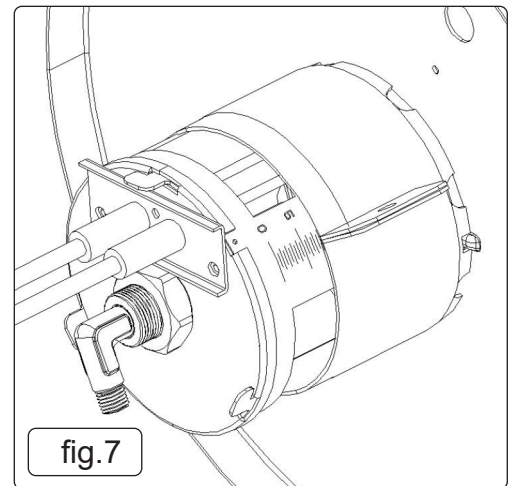

13. TROUBLESHOOTING

Problem	Cause	Remedy
Motor does not start E1 displayed on the screen	No power or low voltage	Check power line and voltage Check fuse and replace if necessary
	Faulty or damaged power cord	Check and replace if needed
	Faulty motor/capacitor	Check and if necessary replace
	Lock-out of appliance due to previous overheating	Detect the cause of overheating Shut the appliance down Check air inlet and outlet Wait some minutes and restart the appliance

E2 displayed on the screen	The temperature probe is faulted or the connector for temperature probe is loose	Check and replace if the temperature probe is needed
Motor runs but the heater does not ignite and locks out after a short time	Empty fuel tank, dirty or wrong fuel	Remove wrong or dirty fuel, refill with clean fuel
E1 displayed on the screen	Ignition fault, dirty or incorrect electrode position	Check and clean electrodes
	Fuel filter clogged	Clean or replace fuel filter
	Burner nozzle clogged	Clean nozzle with compressed air, replace if necessary
	Fuel viscosity increased at low temperature	Mix Diesel with 10-20% kerosene
Heater starts but combustion is not good	Insufficient airflow into combustion chamber	Check air inlet, fan, motor and air collar position, adjust it if necessary.
	Wrong fuel pressure	Check fuel pressure, adjust it if needed
	Leaks in fuel line	Check and fix fuel leaks
Heater stops during operation Ambient temperature displayed on the screen	The room temperature set on room thermostat has been reached	Normal operation To start turn the temperature control knob clockwise to a higher setting
Heater stops during operation E1 displayed on the screen	Flame failure	Check and remove the cause(s) of malfunction To reset, turn On/Off switch to 0 and then to I Call technical service if the problem persists
	Bad combustion	
	Bad combustion	
	Overheating	
LC displayed on the screen	Failure to ignite 3 times will lock the PCB and heater will not work	With mains power on turn On/Off switch off and on 3 times in 10 seconds, to unlock



WEEE REGULATIONS

Dispose of this product at the end of its working life in compliance with the EU Directive on Waste Electrical and Electronic Equipment (WEEE). When the product is no longer required, it must be disposed of in an environmentally protective way.

Contact your local solid waste authority for recycling information.



REGISTER YOUR PURCHASE HERE



ENVIRONMENT PROTECTION

Recycle unwanted materials instead of disposing of them as waste. All tools, accessories and packaging should be sorted, taken to a recycling centre and disposed of in a manner which is compatible with the environment. When the product becomes completely unserviceable and requires disposal, drain any fluids (if applicable) into approved containers and dispose of the product and fluids according to local regulations.

Note: It is our policy to continually improve products and as such we reserve the right to alter data, specifications and component parts without prior notice. Please note that other versions of this product are available. If you require documentation for alternative versions, please email or call our technical team on technical@sealey.co.uk or 01284 757505.

Important: No Liability is accepted for incorrect use of this product.

Warranty: Guarantee is 12 months from purchase date, proof of which is required for any claim.

Jack Sealey Ltd t/a Sealey Group, Kempson Way, Suffolk Business Park, Bury St Edmunds, Suffolk, IP32 7AR UK
Jack Sealey (EU) Ltd t/a Sealey Group, Farney Street, Carrickmacross, Co. Monaghan, A81 PK68 Ireland
Tel: 01284 757500 - **Email:** sales@sealey.co.uk - **Web:** www.sealey.co.uk